

Impact of EV fast charging stations on the power distribution network of a Latin American intermediate city

L.G. González*, E. Siavichay, J.L. Espinoza

Departamento de Ingeniería Eléctrica, Electrónica y Telecomunicaciones – DEET, Facultad de Ingeniería, Universidad de Cuenca, Ecuador

ARTICLE INFO

Keywords:

Fast charging station
Sustainable mobility
Power distribution network
Electric vehicle (EV)

ABSTRACT

One of the most important challenges to mitigate global climate change is to move towards sustainable mobility. In this line, electric vehicles are currently an efficient and environmentally friendly means of transport. The objective of this research is to analyze the incidence of implementing fast charging stations for electric vehicles in the power distribution system of a Latin American intermediate city. The paper covers social, geographic, and technical aspects to determine the minimum infrastructure needed for the selected case study. The analysis is carried out by computational tools in order to model a 50 kW fast charging station with an AC/DC and DC/DC power converter. The inclusion of this type of stations in one of the feeders of the power distribution system of the city of Cuenca, Ecuador, is studied. After the analysis, it can be concluded that the impact of the inclusion of fast charging stations in the distribution system of the study area is reduced in terms of harmonic distortion and energy capacity. This low technical impact can lead to economic and environmental benefits for the city. This study helps to establish the necessary procedure to determine the fast charging infrastructure in urban centers and verify its impact on the power distribution network.

1. Introduction

In response to various international treaties, such as the Kyoto Protocol or the Paris Agreement that seek to reduce greenhouse gases in order to mitigate climate change, new technologies have been proposed to contribute to sustainable mobility. This initiative is relevant given that the road transport sector consumes around 49.7% of oil derivatives [1] and is responsible for 24% of CO₂ emissions worldwide [2]. In the case of the city of Cuenca, Ecuador, 62% of the fossil fuels used in the city goes to transport, while that sector is responsible for 58.4% of total CO₂ emissions [3]. Conventional internal combustion engine vehicles (ICE) emit between 400 and 450gCO₂-eq/mile [4]; therefore, if a vehicle of the city studied presents on average a daily route of 36 km/day, this could represent between 9 and 10.12 kg CO₂/day. Many cities of the world face important challenges due to the exponential growth of private conventional cars and are moving towards policies that promote sustainable mobility. Some of these challenges are: increasing the quality of public transport, improving urban planning, and promoting shared transport or massive use of bikes. Electric vehicles (EVs) are a clear complement to the aforementioned actions because EVs promote the change towards the use of an efficient and environmentally friendly means of transport. However, any policy aimed at sustainable mobility must recognize that public resources are scarce and must be prioritized

towards the most profitable initiatives [5].

The shift towards sustainable mobility is an even greater challenge in developing countries as population growth is generally accompanied by an increase in income levels, which could lead to a greater number of conventional automobiles in those countries. In the Latin American region, for example, between 2010 and 2015 the population growth rate was 1.05% per year [6], while the rate of new vehicles in the same period was an average of 10.6 cars per thousand inhabitants. In 2016 alone, 5.4 million new units were registered in Latin America [7].

Particularly in Ecuador, the population growth of the last decade was 1.4% per year [6], while the automotive fleet from 2010 to 2015 grew 57% [8], that is, over 11% per year. In 2017, sales of new vehicles reached 103 thousand units [9], giving a rate of vehicle per capita of 6 new units per thousand inhabitants, thus having a fleet of about 2.3 million vehicles registered [10]. Only in the city of Cuenca, it is estimated that more than 115,000 units circulate through it.

On the other hand, with the change of the energy matrix promoted by the Ecuadorian Government in the last decade, large power generation projects, mainly hydroelectric, were introduced to expand the country's installed power capacity to 8000 MW [11]. This increase of energy supply has allowed the country to consider electricity from renewable sources to be used in sectors, such as cooking and mobility, previously dominated by fossil fuels. As a result, multiple projects have

* Correspondence to: Departamento de Ingeniería Eléctrica, Electrónica y Telecomunicaciones, Av. 12 de Abril & Agustín Cueva, Cuenca CP: 010150, Ecuador.
E-mail address: luis.gonzalez@ucuenca.edu.ec (L.G. González).

been launched to promote the use of EVs in the main cities of Ecuador. Examples of this are the demonstrations of electric buses in Quito and Guayaquil, the promotion of the use of EV in the Galapagos Islands [12], as well as the introduction of the first fleet of electric taxis in Loja. In Cuenca, the first steps have also been taken to introduce EVs in its transport sector [13,14].

However, one of the aspects that affects the wide acceptance of the EV as a means of transportation to replace internal-combustion engine vehicles is its range of autonomy [15]. Some manufacturers offer EV with autonomies between 150 km to 250 km on average, and exceptional cases such as those offered by Tesla can reach up to 498 km in its recent model 3 [16]. However, in [17], it is indicated that automobile manufacturers overestimate the autonomy range of their vehicles, or that it is estimated under unrealistic conditions. Although the autonomy that most manufacturers present may be sufficient for daily urban use in many Latin American cities, with medium or high densities and relatively short travel distances [5], the problem of autonomy is not completely solved. In this sense, there are initiatives of world-class laboratories such as the NREL [18], which has research groups on transport seeking to provide solutions to mobility problems from a technological approach. In Latin America, laboratories with adequate infrastructure for the study of electric mobility are also emerging, as is the case of [19,20].

Considering the potential high penetration of EVs, which would lead to an increase of electricity demand [21,22], the infrastructure to implement power supply systems has been created in various cities of the world. This infrastructure includes both slow EV charging stations and fast EV charging stations. The most common installations are those fed from the available distribution power system and, in other cases, supplied by alternative renewable energy sources as presented in [21,23,24] and specifically in [25] where the authors study the interaction between solar energy and electric mobility as a disruptive technology. These infrastructures, analogous to those established for internal combustion vehicles, are classified according to the level of energy they can handle. The slow charging stations are the most widely used worldwide, with a power range between 5 and 7 kW. They are designed for residential applications, generally at acquisition costs of less than US \$ 1000 per station. Of equal importance are charging stations for public use, which allow the reduction of the range of anxiety [26], managing in turn a greater amount of energy in order to obtain a shorter charging time. The capacity of these stations to charge the EV batteries in less time is greater than 19.2 kW [27]. For this reason, they are called fast charging stations with costs that depend on their capacity. The reference price can be in a range of 10,000–40,000 USD for a 50 kW power station [28]. However, the effect of delivering more energy to an EV in a shorter time leads to technical problems for the charged batteries, such as greater heating, directly increasing their degradation and reducing their useful life [29]. Studies on the impact of fast charging on EV batteries have shown that, with the exclusive use of fast charges, after 100 thousand miles of travel, batteries can lose up to 2.6% of their capacity due to deterioration [29]. That is why the use of a fast charging system must be done under justified conditions, for example, for a long trip or emergency situations.

EV fast charging stations in urban centers are usually arranged geographically in groups, which can operate simultaneously powered by the same transformer from high or medium voltage levels from the available distribution power system. Case studies have been carried out to analyze the impact on distribution systems caused by the inclusion of EVs as loads, as well as the effect of EVs as eventual storage systems supporting the distribution network under conditions of high demand, known as vehicle to grid – V2G [30–33].

This paper analyzes the impact of EV fast charging stations on the distribution power system of an intermediate Latin American city, as is the case of Cuenca, Ecuador. The study focuses on determining the incidence of including a set of level 3-fast charging stations in a selected area of the city, considering the capacity of the electrical system and the

variation in the power quality that this set of stations can cause. This document is organized as follows: Section 2 deals with the different charging systems classified by the level of energy they can handle and by the communication system with the EV during the loading process. In Section 3, aspects related to the estimation of the urban and inter-urban infrastructure necessary to allow the operation of EV in an intermediate city are studied. In Section 4, modeling of a fast charging station is carried out using a 2-level Voltage Source Inverter (VSI) controlled by a three-phase rectifier topology and an isolated DC / DC converter, according to the practical recommendations in [34] and the modeling of a battery bank of an EV. In Section 5, the case study is detailed, including some recommendations for the geographical location of fast charging stations in the selected city. In Section 6, the impact of including EV fast charging stations on the electrical distribution system is studied, whereas Section 7 presents the conclusions of the study.

2. Overview of EV charging stations

EV charging stations are responsible for providing and controlling the energy that is transferred to the vehicle's battery. For example, level 3 charging stations [35] perform energy management under load regimes that allow extending the useful life of the battery and maintaining adequate operating conditions in the power distribution network. In order to establish the standardization among diverse brands of EV chargers, the Society of Automotive Engineers (SAE) and the International Electrotechnical Commission (IEC) have categorized different types of electric chargers, according to their power levels and charging mode.

2.1. According to the power level

In its standard “SAE Surface Vehicle Recommended Practice J1772, SAE Electric Vehicle Conductive Charge Coupler” [36], SAE establishes several aspects regarding charging technologies, electrical specifications, and charging protocols. It also classifies the charging stations according to their power levels. Based on this standard, there are 3 power levels for the EV charging stations [36]:

2.1.1. Level 1

This level is used in residential power networks with nominal voltage of 120 VAC, single phase, including overcurrent protections and a ground fault interrupter. It handles power levels lower than 2 kW and currents up to 12 A [37]. This level implies a high charging time of the EV, between 6 and 24 h. Under this load level, the energy conversion is performed by the EV converter.

2.1.2. Level 2

Level 2 uses a connection of two or three phases with voltages between 208 and 240 VAC, a capacity of 7.6 kW and a current of up to 32 A. The charging time of the EV could be less than 6 h depending on the load level and initial charge status. The charging station is protected with ground fault interrupter [37]. The energy conversion, as in the previous case, is carried out by the on-board EV converter, which is responsible for the harmonic distortion of current at the connection point. At this charging level, communication is established between the station and the EV, defining the maximum operating power, and it has been materialized by the connectors identified in the standards IEC62196-2 Type 1, IEC 62196-2 Type 2 and GB / T 20234.2.

2.1.3. Level 3

In this category, the so-called fast charging stations are included, the topic of study in this document. The maximum energy that this segment can handle is 240 kW with currents up to 400 A. Depending on the EV, the charging time can be less than 30 min to reach 80% of the capacity of the battery bank. At this level, the stations are responsible for

Table 1
EVs Charging Modes, according to IEC 61851-1.

Characteristic	Mode 1	Mode 2	Mode 3	Mode 4
Type of voltage for EV charge	AC (1F o 3F)	AC (1F o 3F)	AC (3F)	DC
Current (A)	16	32	32/250	400
Communication between the station and the EV	There is no communication	Control signal and proximity	Control signal and proximity	Control signal and protections, CAN protocol and others
Connector	Type A, Nema 1/ Type F Schuko	SAE J1772, Mennekes,	SAE J1772, Mennekes, CCS, Scame, GB/T 20234.2	CHAdEMO, CCS
Protections	Differential and Magnetic Protections	Differential and Magnetic Protections	Included in the Electric Vehicle	Included in the charger
On-Board energy conversion	Yes	Yes	Yes	No

carrying out the power conversion AC / DC; the voltage provided by these stations is DC type and reaches up to 600 V. The operating voltage depends exclusively on the EV's battery bank due to its direct connection to it [37]. Under this load level, connectors can be used under standards SAE J1772, CHAdEMo, IEC 62196 type 2 (commonly called combo), among others.

2.2. According to the charging mode

The charging mode describes the communication protocol between the EV and the charging stations. This type of classification for the charging process is described in the standard IEC 61851-1 [38]. The established modes are described in the Table 1.

3. Estimation of Urban and Interurban Infrastructure for EV operation

Regarding the necessary infrastructure for a minimal coverage for the operation of an EV fleet in a city, there are charging stations of levels 1, 2, and 3. Level 1 and 2 stations are mainly used in residential and commercial zones for long stay, while those of level 3 allow an EV charge in less time. It is necessary to quantify these charging stations under two well-defined scenarios.

3.1. As energy backup in high density areas of EV (Metropolitan areas)

In [39] statistics are presented on the quantities of DC fast charging stations according to the population, where cities such as San Jose or San Francisco in the USA have about 30 stations per million inhabitants, presenting an EV penetration of 9.4% and 5.3%, respectively [40]. Under this assumption, the city of Cuenca with a population close to 500,000 inhabitants could operate with 15 fast charging stations. In another study [41], the stations are estimated by the number of EV and other considerations, with the result that the maximum necessary range is between 1 and 2 stations per 1000 EV. In this sense, with a 10% penetration of EVs in Cuenca, about 23 stations would be required.

In [42] another alternative is presented to determine the quantity and location of the fast charging stations, which is optimized with the use of genetic algorithms. The location of these stations is a function of the number of jobs and homes in the area that may have EV. Some studies also indicate that fast chargers are not only used in long-distance travel. In [43] it is shown that 50% of the users of fast charging stations have their homes at a distance of less than 20 miles. Also, around 10% of the charging sessions have passed the point of no return (half the range of a vehicle autonomy) and only 1% are beyond the reach of a vehicle autonomy (they need additional energy to reach home). The behavior of drivers when using the fast charging mode indicates that they present a complementary use to level 1 and 2 stations, reaching the desired charge in a few minutes. This behavior shows that, although they can be in the vicinity of the other types of charging stations (Levels 1 and 2), EV drivers make frequent use of fast chargers.

3.2. As energy backup in inter-urban communication routes (Highways)

Regarding the energy charge on interurban roads, the needs are basically subject to the autonomy of the EV. As for the infrastructure of internal combustion vehicles, to establish a point of reference, there are 1059 service stations throughout Ecuador [44]. These stations distribute Gasoline and Diesel and they are located mainly in 10,000 km of primary and secondary roads [45] plus urban centers, of which only 558 km belongs to the Province of Azuay, whose capital is the city of Cuenca. The interurban road network of Ecuador can be observed in Fig. 1. Although in Ecuador there is no single regulation for the location of fuel supply service stations, a density of one station per 267 km² can be roughly estimated, and of 9.4 km between stations in terms of average distance if they were distributed evenly on the roads. In this sense, in [46] the minimum infrastructure for interurban roads is determined, where the Basic Highway Charging Infrastructure (BHCI) is calculated by an estimate based on both the total kilometers of primary and secondary roads in the country (Total network length – T_n) and the Maximum Distance between Fast Charger (MDFC). This last parameter is derived from a study of the EV's autonomy, taking into account aspects such as: weather conditions, average speed on the roads, among others [46]. In different studies this parameter is used with a magnitude of 60 km of autonomy. From Eq. (1), a preliminary estimate of the minimum infrastructure for Ecuador is calculated, obtaining approximately 166 fast charging stations, only for interurban areas.

$$BHCI = T_n / MDFC \quad (1)$$

When the same Eq. (1) is applied for Azuay province, 9 fast charging stations are obtained, of which at least 5 should be located in the Cuenca canton, considering its extension with respect to the other 14 cantons that constitute the province.

By applying the statistics used in the aforementioned studies, the infrastructure necessary for the EV's fast charging mode, level 3, is indicated in Table 2. The assumption for the maximum case presented in Table 2 is obtained by considering the EVs penetration of 10% in the automotive fleet of the city under study.

In economic terms, the cost of the necessary infrastructure could reach approximately 1.2 million dollars. This initial investment is equivalent to 650,000 gallons of fuel in Ecuador, which represents the energy needed to supply only 1.6% of the total vehicle fleet in the city of Cuenca for one year. In [47] the cost of infrastructure for fast charging stations with a capacity of 50 kW is estimated between 0.11 and 0.14 EUR/kWh with a repayment term of 10 years, without taking into account the cost of energy. In the case of Ecuador, with electricity cost of 0.093 USD/kWh, the cost of using a fast charging station would be between 0.22 and 0.26 USD/kWh.

4. Modeling of the EV fast charging station

The EV charging station here studied corresponds to level 3 according to [36]. An AC/DC energy conversion system that complies with the CHAdEMO standard has been modeled in this section. For this

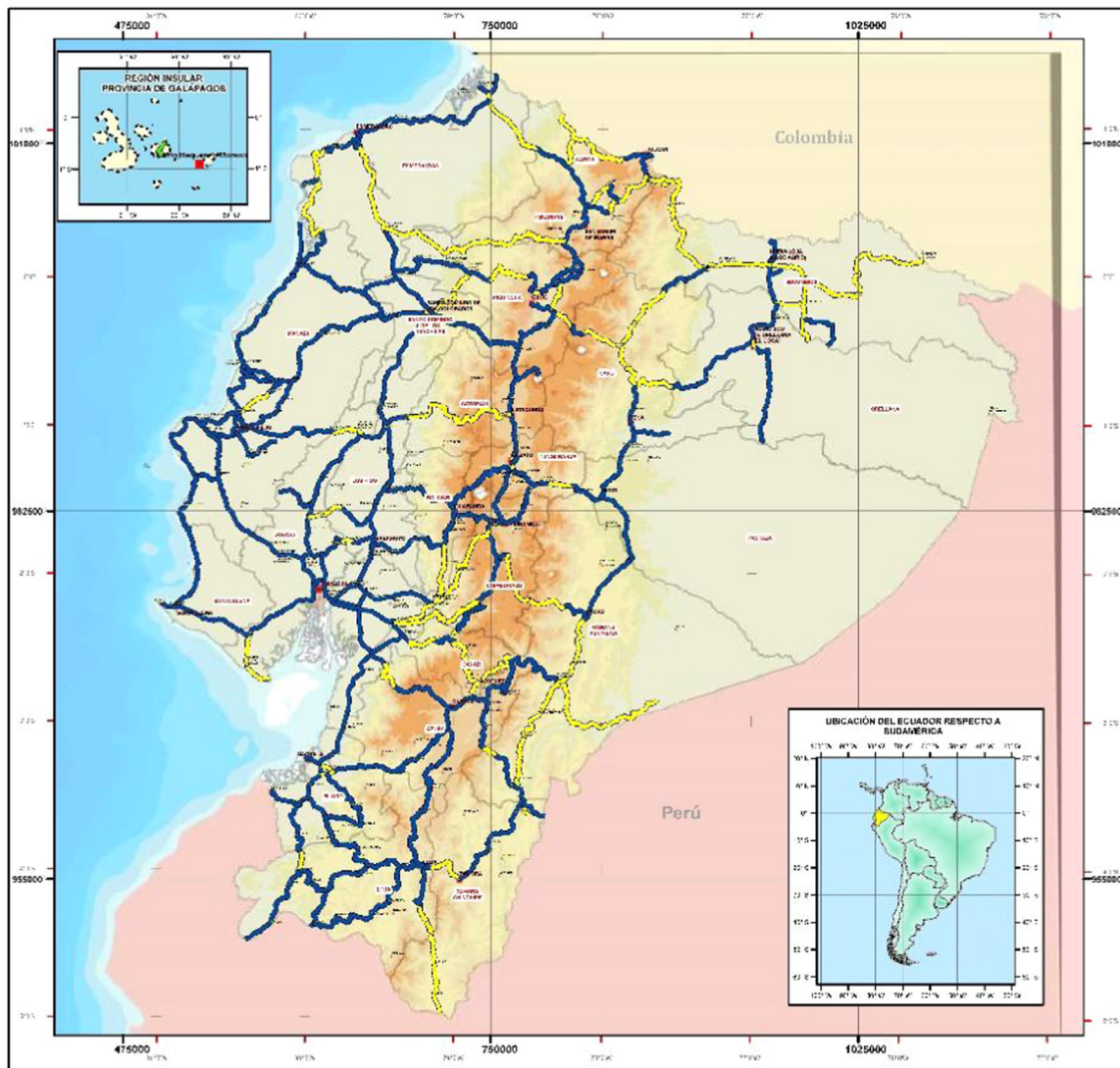

Fig. 1. Ecuador's Interurban road network [45].

Table 2
Necessary infrastructure for fast charging stations (DC level 3) in the city of Cuenca.

Infrastructure	Min	Max	Method Max/Min
Urban	15	23	[39,41]
Interurban	5	–	[46]

type of stations, an additional galvanic isolation and a supply of a three-phase AC system of 380 V with nominal power of 50 kW is required. Within the CHAdeMO standard, the station allows battery banks to be charged in direct current – DC with variable voltage between 50 V and 500 V and maximum current of 125 A. The energy processing scheme of the charging station is proposed in [34]. Although the CHAdeMO standard does not define the type of power converters to be used, it recommends a charge under the maximum current limitation called constant current (CC) at 125 A. In its latest versions, the standard proposes a charging process at 150 kW-350A, called the high-power version in DC charge [48]. Charging at constant current occurs until the nominal battery bank voltage is reached, and then under the constant voltage regime (CV) until the battery reaches its nominal capacity. Usually under the charge regime in CC, approximately 80% of the state of charge (SOC) is reached in a few tens of minutes depending on both

the initial state and the capacity of the battery in charge. Finally, the full charge is obtained when the nominal battery voltage is reached with a maintenance current defined by the EV.

4.1. Topology of conversion AC/DC + DC/DC

The CHAdeMO standard recommends to have reinforced insulation or double insulation [34], which implies using energy conversion systems that allow it. There are several ways to meet this requirement through low frequency transformers located in the AC input of the power converter, or transformers to operate in high frequency associated with DC with better size and efficiency. The modeled charging station is powered by a three-phase 380 V @ 60 Hz system, and it has a three-phase complete bridge rectifier with two levels [49], that supplies a 800 V DC bus with a 5 kHz switching frequency coupled to a LCL passive filter type [50] with $L = 0.55 \text{ mH}$, $L_g = 80 \mu\text{H}$, $C_f = 251 \mu\text{F}$, $R_d = 0.17 \Omega$, with a resonance frequency of 1.2 kHz. The charging station controls the line currents with the use of the dq synchronous reference system with independent control loops of reactive-active current. Additionally, it uses a phase synchronization system $PLL-dq$. Regarding the DC / DC conversion, a full bridge converter is used in [51] and [52] with a high frequency transformer that meets a double insulation. This stage allows the energy control towards the battery

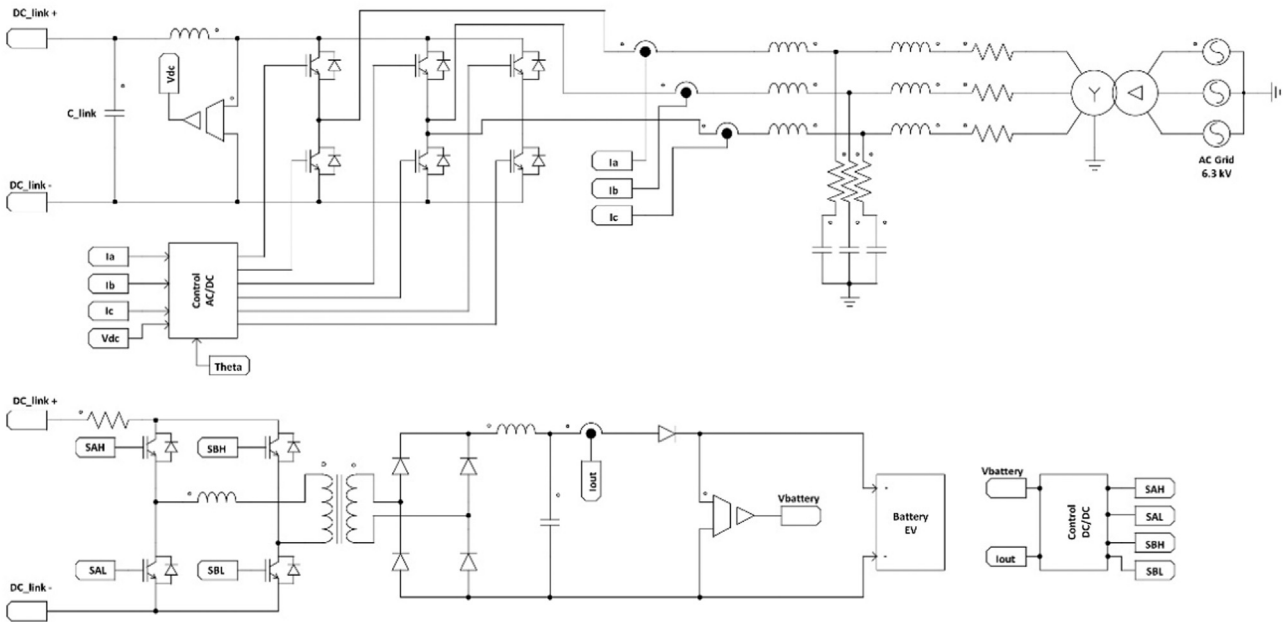

Fig. 2. Rectifier VSI-Converter full Bridge + DC/DC converter.

bank of the EV operating in the constant current and constant voltage regimes. Fig. 2 shows the AC/DC and DC/DC conversion scheme described above.

4.2. EV Fast Charging station behavior under nominal operating conditions

With the use of the computational tool *Psim*[®] [53], the modeling of the AC/DC and DC/DC power converter shown in Fig. 2 was performed, considering a bank of Lithium-Ion batteries with nominal voltage of 360 V studied in [54], with a capacity of 75 Ah. In Fig. 3 the charging behavior of the battery bank is shown with an initial charge status of 15% up to 95%. The time of this charge is 31 min, storing approximately a capacity of 22 kWh, where the initial voltage is 350 V, with 15% SOC. The constant current mode can be observed in Fig. 2, which is limited to 125 A according to the CHAdeMO standard. After 26 min of charge, the constant voltage mode is operated at 412 V. In this operation mode, the charging current decreases until the desired state of charge is reached.

For the purpose of analyzing the behavior at the point of common coupling (PCC) between the charging station and the power distribution system, the maximum load power is 50 kW at $t = 26$ min, which coincides with the transition between the modes of both constant voltage and constant current. Under this condition of operation, the current *rms* in the PCC is close to $i_a = 877$ A with $THD = 0.904\%$, where the main

Table 3

Amplitude of harmonics of the input current to the AC / DC converter.

Harmonic	Frequency (Hz)	Amplitude <i>rms</i> (A)
1	60	86.73
5	300	0.834
7	420	0.24
13	780	0.18
17	1020	0.38

spectral components are described in Table 3.

Due to the characteristic of the LCL passive filter used and the amplitudes of harmonics shown in Table 3, the spectral density close to switching frequency ($f_{sw} = 5$ kHz) is attenuated completely in comparison to those of order 17 that are located at a frequency of $f_{N=17} = 1.02$ kHz.

5. Case study

The city of Cuenca was chosen for the present study. Cuenca is the third city in importance in Ecuador, after Quito and Guayaquil. Unlike the other two cities that have a population of more than two million each, Cuenca, with approximately 500,000 inhabitants [55], is considered an intermediate city and represents the vast majority of cities,

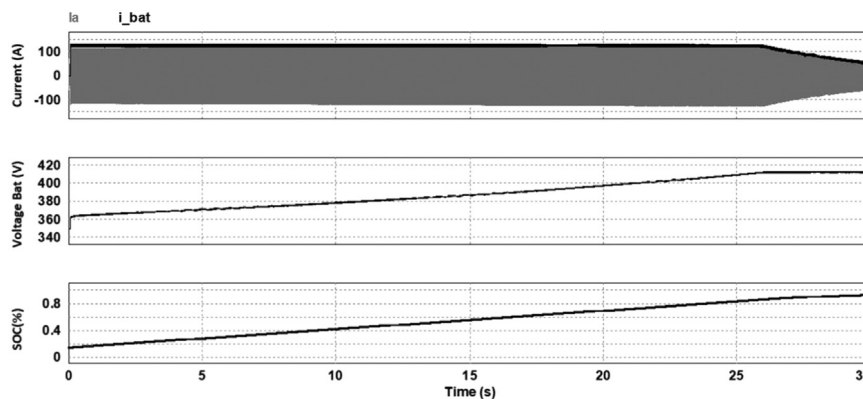

Fig. 3. Fast charging station behavior.

not only in Ecuador but in Latin America. An intermediate city is one that has more than 100,000 inhabitants but does not exceed one million, and which presents important characteristics to provide a better quality of life for its citizens. Among these characteristics, when compared to large cities, are an acceptable degree of citizen participation (for example, at the neighborhood level), less social conflict, good urban-rural links, fewer environmental problems, among others [56].

In addition, like the rest of cities in Ecuador, Cuenca has a good electricity service, which reached 98% coverage in the urban area in 2016 [57]. Due to the level of electricity coverage that Cuenca has, it is important to estimate the impact of a number of EV fast charging stations on a power substation that feeds part of the city, at the connection point with a feeder. This number could be variable depending on the growth of the EV's fleet. Initially, the study location should have one station, although the study's worst case scenario is to consider four fast charging stations. Section 6 presents the justification for the latter scenario. To determine the power feeder under study, several criteria have been taken into account that influence the selection of the location where the charging stations would operate. The most important criteria deal with technical, geographical, and social aspects.

5.1. Criteria for choosing the location of EV fast charging stations

In order to determine the ideal feeder within the existing power distribution system or the area where the charging station should be installed according to the geography of Cuenca, the methodology shown in [58] is used. This method considers different geographical, social, and technical characteristics that a place within a city must fulfill. One of the most important aspects for the selection of the place is to have a considerable visibility. The recommended places for the installation of fast charging stations are shown in Table 4, according to [58]. Among the multiple places for implementation, it is necessary to know the circulation route of vehicles as well as the time of permanence that their users would be willing to remain in each sector.

The characteristics that must be fulfilled when installing fast charging stations are: easy access, sufficient space to park, adequate infrastructure of the electrical system or with the possibility of having an adjacent power grid, close to centers of interest for entertainment purposes or for EV users' own activities.

Another important aspect to consider for the demand and location of EV charging stations is if the vehicles are to be incorporated into the public transport sector. Some initiatives have already been taken in this direction in other cities [12,14,59]. EVs for public transport require, due to their work dynamics, to increase their autonomy in a short time. For example, for electric taxis, the coverage area is relatively similar to that of the urban area of the city where they provide their services. In the case of electric buses, there is a recent interest in Latin America to include these vehicles in cities' urban sectors due to the reduced pollution they generate, compared to other technologies [60].

In the case of Cuenca, there are approximately 3500 taxi units with an average daily route of 170 km [61], and 465 buses with travel averages of 250 km/day. As a reference, one taxi in the city of New York travels on average 205 miles/day [62] which, if the service were to be provided in an EV, it would need a partial charge to meet the average daily travel in case of not fulfilling this autonomy.

Table 4
Places of High Vehicle Circulation [58].

Universities	Health Centers	Hotel areas
Commercial Malls	Recreational parks	Department store
Governmental Offices	Public transport stations (Terrestrial and aerial terminals)	Public entertainment areas (Stadiums, theaters, etc.)

5.2. Definition of the location for EV fast charging stations in Cuenca

Cuenca has an approximate perimeter of 45 km and a metropolitan area of more than 70 km² where its half million inhabitants live. The city is located in the upper part of one of the most important watersheds of Ecuador in terms of hydroelectric generation, the Paute river basin. The city has a variety of spaces that meet the basic characteristics of an EV charging point. However, the lower part of the city stands out with an approximate area of 0.3 km² delimited by Fray Vicente Solano Avenue, 12 de Abril Avenue, Paucarbamba and Manuel J. Calle Streets, belonging to the Huayna Capac Parish. According to the study carried out in [63], it is estimated that at least 55 thousand vehicles circulate daily through Solano Avenue. Also, in this sector there are spaces of high concurrence of people such as the Alejandro Serrano Aguilar Stadium, the shopping malls Milenium Plaza and El Vergel, Azuay's Court of Justice building, Parque de la Madre (Mother's Park), as well as the Santa Ana and San Juan de Dios medical centers, all of them with the characteristics mentioned in Table 4. Specifically, Parque de la Madre's parking lot presents the following characteristics:

- It is a public space under municipal administration; therefore, this would facilitate the implementation of charging stations for public use.
- It is easily accessible by 12 de Abril Avenue and Florencia Astudillo Street and has the largest number of parking spaces in the sector.
- The capacity of the location is 190 parking spots, distributed as follows: 150 located in the underground area and 50 at street level; this allows the allocation of exclusive spots for EV charging stations.
- It is open to the public 24 h a day from Wednesday to Saturday and from 6 A.M. to 10 P.M. the rest of the week.
- It has 24-h surveillance, providing fast charging stations with protection against vandalism.

5.3. Power distribution system in the study sector

The power distribution system of the study area corresponds to the feeder # 0204 with a high voltage level of 6.3 kV. The system belongs to the local electrical distribution company, Centrosur. The feeder starts from Substation # 2, located in El Centenario sector whose coordinates are (−2.901320, −79.005834) and has a power nominal capacity of approximately 4 MVA.

Fig. 4 shows the geographic coverage of the feeder # 0204 in the study area; additionally, the current capacity in the different areas of the distribution system can be observed, as well as the nodes of interest for this study. The lines near the head of the feeder have a capacity of more than 250 A, whereas the most distant lines and branches have a capacity greater than 100 A. All of them have a voltage of 6.3 kV between lines.

6. Analysis of the impact of EV fast charging stations in the study zone

In order to analyze the possible impacts of implementing a set of fast charging stations, the method shown in [64] is considered. The authors present several scenarios and use the IEEE 33 bus test system standard, represented as a radial distribution network. By including fast charging stations in the network, the study analyzes variables such as voltage stability and power losses.

In this paper, that considers the scale of a Latin American intermediate city, the variables studied in [64] are analyzed based on real information from one of the feeders of the city's distribution system. The number of stations under study is obtained from the assumption that the # 0204 feeder supply area covers approximately 0.5% of the area of the city of Cuenca. This corresponds to one station out of the 23 needed according to [41], considering an EV penetration of approximately 10% of the vehicle fleet. However, due to the high growth rate

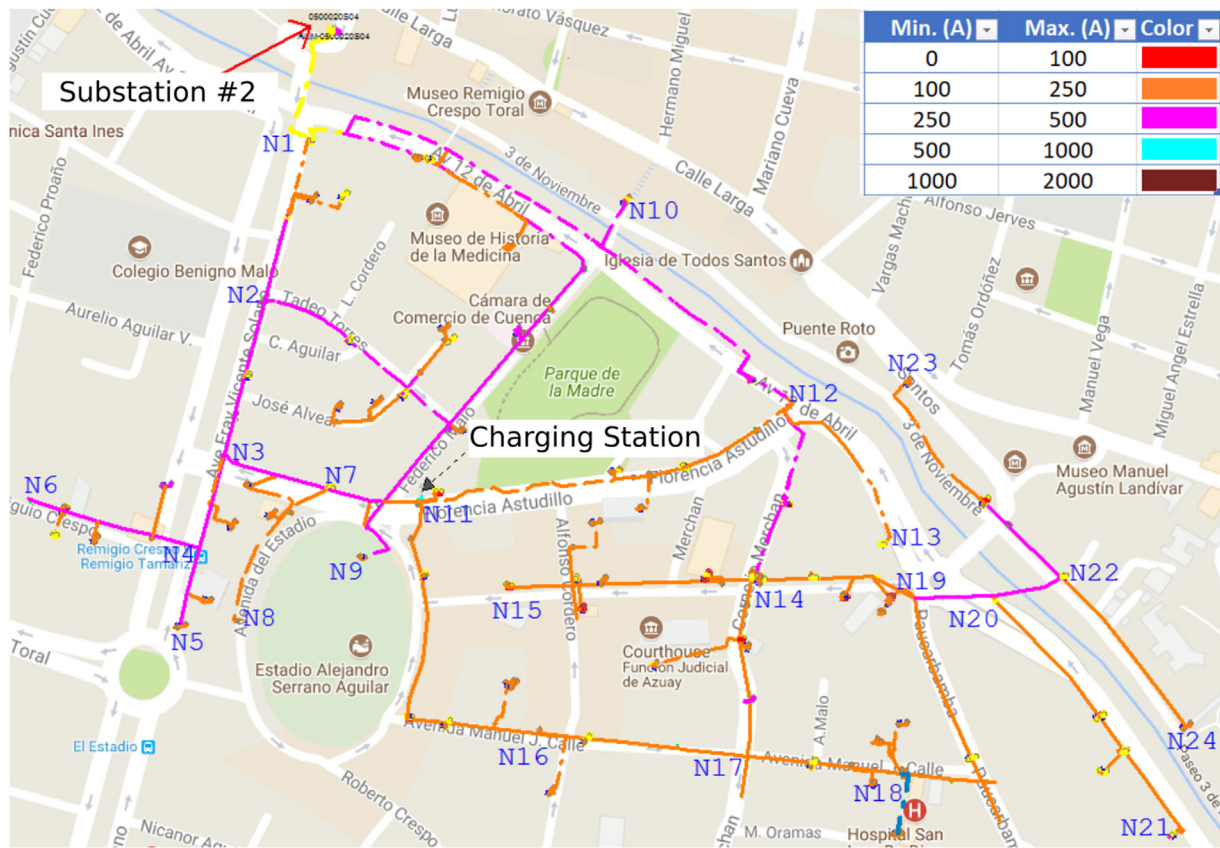

Fig. 4. Coverage area of Feeder # 0204 and current levels.

of the Ecuadorian automobile fleet and assuming an EV's penetration rate of 40%, in this analysis four (4) fast charging stations have been arranged in the chosen site. The stations represent a load of 200 KVA in the service area of the feeder # 0204. A graphical and analytical analysis was developed in the study, starting with the current conditions of the selected area. The process used the CYME software and the modeling of the power distribution system of the area was done with the technical data provided by Centrosur.

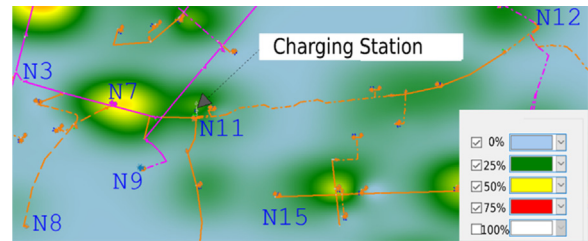

Fig. 6. Installed load density with fast charging stations.

6.1. Load density in the study zone

This section analyzes the load density in the area covered by the feeder # 0204 by means of the maps of Figs. 5 and 6, where the density is observed without and with the inclusion of the charging stations, respectively. When contrasting the two images, a slight increase can be observed in the load density surrounding the N11 node, in which the stations operating at nominal capacity were included. However, this increase is clearly marginal if it is contrasted with the densities of the other loads installed in the adjacent areas, which do not exceed 75% of their nominal capacity.

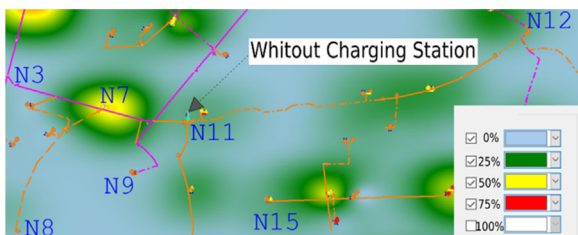

Fig. 5. Installed load density without fast charging stations.

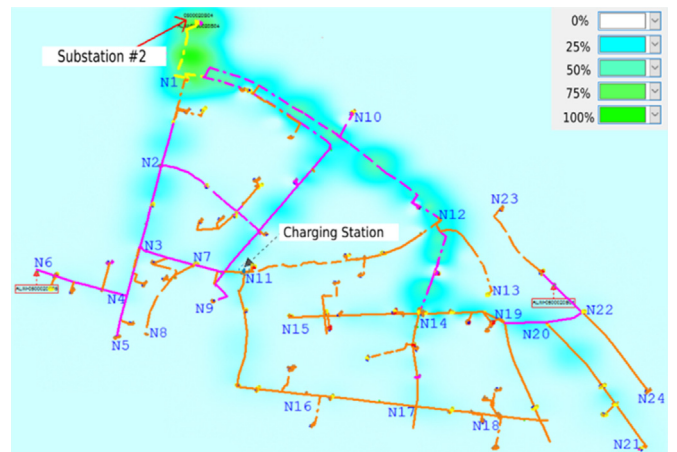

Fig. 7. Power density in the study area with the inclusion of EV charging stations.

Table 5
Apparent Power Flow in Feeder #0204.

Apparent power			
Line	Without charging stations (kVA)	With charging stations (kVA)	Power increase
N1_N	7678	7886	2.71%
N1_S	1367	1367	0.00%
N1_E	6264	6469	3.27%
N2_N	1198	1198	0.00%
N2_S	1196	1196	0.00%
N3_N	748	748	0.00%
N3_S	336	336	0.00%
N3_E	406	406	0.00%
N7_S	0	0	0.00%
N7_E	10	10	0.00%
N7_O	386	386	0.00%
N10_S	89	89	0.00%
N11_S	514	514	0.00%
N11_E	266	266	0.00%
N11_O	851	1054	23.85%
N12_NO	3973	3973	0.00%

6.2. Loadability in transmission lines

In order to avoid lines overloading and to know the power density with the increase of the load, the power density that would exist in the feeder lines after the inclusion of the charging stations has been studied. Fig. 7 shows that the highest power density is found in the header of the feeder, in the nodes N1-N10-N12-N14-N20 and N1-N2-N3.

It is important to note that the capacity of the feeder does not reach its nominal power, and with the exception of the head of the feeder, in most of the lines the power density is only 50% of the nominal capacity.

6.3. Changes in flows of the feeder apparent power

To identify the lines that are part of the feeder, they have been named with reference to the node that they are linked to and the cardinal direction to which they are oriented from the node. Since the apparent power is the combination of both active power and reactive power, it can be observed in Table 5 that the increase of the header lines N1_N and N1_E does not exceed 3.27%, a value that shows the low incidence of the proposed charging stations on the feeder under study. As regards to the N11_O line, this has an increase of 23.85% of its load flow, due to the direct connection of the fast charging stations.

6.4. Voltage levels in the study zone

In order to analyze the voltage levels that exist in the different sectors of the selected feeder, a degradation of colors is used, where each color represents percentage values of a voltage base of 6.3 kV. Fig. 8 shows the current voltage levels of the feeder and Fig. 9 shows the voltage levels of the feeder with the implementation of the four fast charging stations.

To have a more detailed analysis, Table 6 presents that the maximum voltage drop occurs at node N21 because it is one of the most distant from the feeder, where it goes from 2.97% to 2.98%, noticing a negligible increase due to the inclusion of the charging stations. The nodes that showed the greatest change in their voltage are N11 and N16 with an increase of 0.11% in their voltage drop. This indicates that the changes can be considered of low impact on the operating conditions of the power grid.

When contrasting Figs. 8 and 9, it is observed that the fast charging stations generate a voltage drop of up to 0.5% in the lines between the nodes N20-N18, N11-N16 and close to node 14, which are indicated by green arrows in Fig. 9.

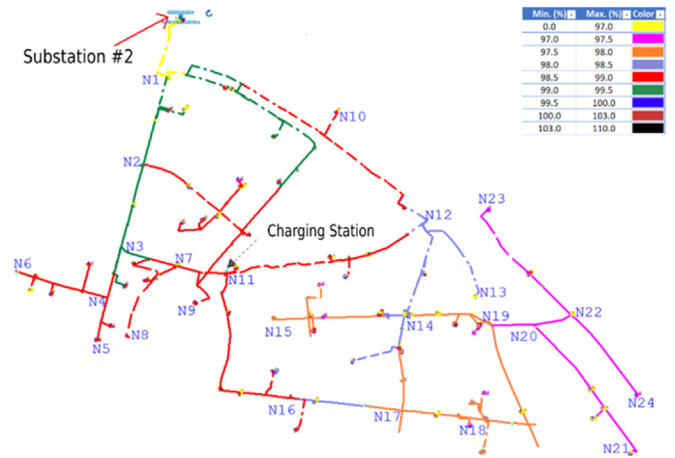

Fig. 8. Voltage levels without charging stations.

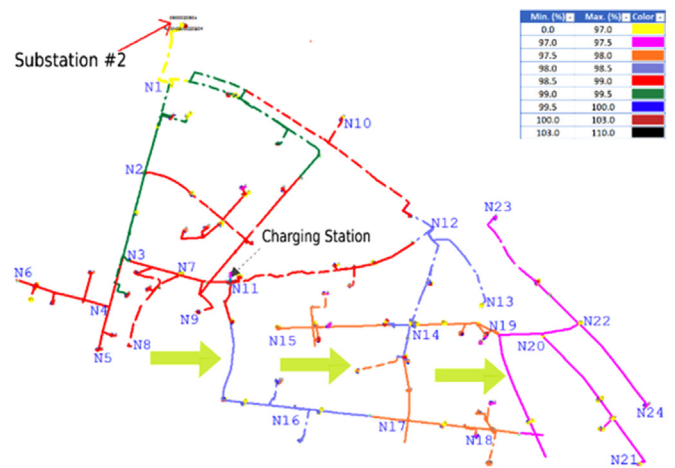

Fig. 9. Voltage levels with charging stations.

Table 6
Voltages in the nodes of Feeder #0204.

Node	Current conditions		With fast charging stations	
	Voltage L-L (kV)	Voltage drop	Voltage L-L (kV)	Voltage drop
N01	6.269	0.49%	6.268	0.51%
N02	6.225	1.19%	6.22	1.27%
N03	6.239	0.97%	6.238	0.98%
N04	6.237	1.00%	6.236	1.02%
N05	6.236	1.02%	6.235	1.03%
N06	6.234	1.05%	6.233	1.06%
N07	6.236	1.02%	6.234	1.05%
N08	6.236	1.02%	6.234	1.05%
N09	6.235	1.03%	6.234	1.05%
N10	6.229	1.13%	6.228	1.14%
N11	6.219	1.29%	6.212	1.40%
N12	6.201	1.57%	6.2	1.59%
N13	6.197	1.63%	6.195	1.67%
N14	6.177	1.95%	6.176	1.97%
N15	6.168	2.10%	6.167	2.11%
N16	6.206	1.49%	6.199	1.60%
N17	6.172	2.03%	6.17	2.06%
N18	6.168	2.10%	6.167	2.11%
N19	6.146	2.44%	6.145	2.46%
N20	6.137	2.59%	6.135	2.62%
N21	6.113	2.97%	6.112	2.98%
N22	6.134	2.63%	6.133	2.65%
N23	6.133	2.65%	6.132	2.67%
N24	6.134	2.63%	6.132	2.67%

6.5. Harmonic distortion generated by the fast charging stations

Regarding the quality of the energy, specifically the harmonic distortion in the voltage produced by the inclusion of the four fast charging stations, it is almost imperceptible. The analysis determined increases of up to 0.1% and a maximum total harmonic distortion (THD) of 0.8%. There is a decrease of up to 0.01% in the harmonics number 5 and 17 in the node N11 that corresponds to the place where the charging stations are located. In the other nodes, there are also variations of up to 0.01% in the harmonics 5, 13 and 17.

As for the harmonics of current, the comparative analysis of the grid with and without the charging stations shows that these vary in the lines near the load. However, this variation does not exceed 0.7% of the fundamental current. The results on harmonic distortion (voltage and current) are within the ranges acceptable by the IEEE standard 519–2014 [65].

7. Conclusions

This article studies the impact that the installation of fast charging stations would have on the power distribution system of a Latin American intermediate city, based on a case study of the city of Cuenca, Ecuador. It is estimated that 23 fast charging stations could be enough to initially satisfy the urban part of the city for a 10% penetration of EVs (11,500 vehicles). This infrastructure represents an investment of approximately 1.2 M USD with which it would be possible to guarantee the operation of that number of EVs. The investment is very low compared to the amount of fossil fuel energy that would not be used.

It has been determined from the study that the electrical variables of a feeder do not show considerable changes with the inclusion of fast charging stations. For example, the voltage drop does not exceed 0.11%, the power flows through the feeder lines present increases of up to 7.8% in the line that feeds the fast charging stations and less than 1% in the other lines of the feeder, while the variations in the distortion of harmonics are almost imperceptible. After this analysis, it can be affirmed that the technical impact of the fast charging stations for EVs is reduced in the power distribution system of the study area.

The electric utility economic impact would be very low as there is no need to adapt the existing electricity network under the new conditions. As for environmental impacts, it can be mentioned that the higher the EV penetration in the city the lower its CO₂ emissions, moving the city towards a sustainable mobility model. Both economic and environmental impacts need deeper analysis; however, they are out of the scope of this study.

Finally, this study helps to establish the necessary procedure to determine the fast charging infrastructure in urban centers and verify its impact on the power distribution grid. Similar studies could consider the inclusion of EVs (and their corresponding charging infrastructure) in the vehicle fleet of several Latin American intermediate cities.

Acknowledgements

The authors thank the electricity distribution company Centrosur for providing the technical information about Cuenca's power distribution system.

Additionally, the authors thank the Research Department of the University of Cuenca (DIUC) and the Ecuadorian Network of Universities for Research and Graduate Studies (REDU) for their support in the project "Beyond Oil: A Study of the Relationship between Urban Form and transportation in two cities of Ecuador".

Declarations of interest

None.

References

- [1] Key World Energy Statistics 2017. International energy agency. <<https://www.iea.org/publications/freepublications/publication/KeyWorld2017.pdf>> [Accessed 1 March 2018]; 2017.
- [2] CO2 Emissions from Fuel Combustion. International energy agency. <<https://www.google.com/search?Client=firefox-b-d&q=https%3A%2F%2Fwww.iea.org%2Fpublications%2Ffreepublications%2Fpublication%2FCO2EmissionsfromFuelCombustionHighlights2017.pdf>> [Accessed 5 February 2019]; 2017.
- [3] Inventario de Emisiones Atmosféricas del Cantón Cuenca 2014. <https://www.researchgate.net/profile/Rene_Parra/publication/311789933_Inventario_de_Emisiones_Atmosfericas_del_Canton_Cuenca_2014/links/585a977208aebd9a58cd0a7/Inventario-de-Emisiones-Atmosfericas-del-Canton-Cuenca-2014.pdf?Origin=publication_detail> [Accessed 1 March 2018]; 2014.
- [4] Weiller C. Plug-in hybrid electric vehicle impacts on hourly electricity demand in the United States. *Energy Policy* 2011;39:3766–78. <https://doi.org/10.1016/J.ENPOL.2011.04.005>.
- [5] Banco Interamericano de Desarrollo. La incorporación de los vehículos eléctricos en América Latina n.d. <<https://publications.iadb.org/bitstream/handle/11319/7854/La-incorporacion-de-los-vehiculos-electricos-en-America.pdf>> [Accessed 1 March 2018].
- [6] CEPALSTAT Indicador 31 n.d. <<http://estadisticas.cepal.org/sisgen/ConsultaIntegrada.asp?IdAplicacion=1&IdTema=1&IdIndicador=31&Idioma=e>> [Accessed 2 March 2018].
- [7] Automotores AC de V. En 2016 se presentó récord mundial en venta de vehículos n.d. <<http://www.andemos.org/wp-content/uploads/2017/02/Comunicado-Indice-de-Motorizacion-2016.pdf>> [Accessed 1 March 2018].
- [8] Instituto nacional de estadística y censos. El parque automotor de Ecuador creció 57% en cinco años | n.d. <<http://www.ecuadorencifras.gob.ec/el-parque-automotor-de-ecuador-crecio-57-en-cinco-anos/2017/>> [Accessed 2 March 2018].
- [9] El Telégrafo – En. se vendieron 103.000 vehículos n.d. <<https://www.eltelegrafo.com.ec/noticias/economia/4/en-2017-se-vendieron-103-000-vehiculos>> [Accessed 2 March 2018]; 2017.
- [10] Sector Automotor en cifras. 2017. <<http://www.aeade.net/wp-content/uploads/2018/01/boletin15spanolresumido.pdf>> [Accessed 15 March 2018].
- [11] Ponce-Jara MA, Castro M, Pelaez-Samaniego MR, Espinoza-Abad JL, Ruiz E. Electricity sector in Ecuador: an overview of the 2007–2017 decade. *Energy Policy* 2018. <https://doi.org/10.1016/j.enpol.2017.11.036>.
- [12] Clairand J-M, Arriaga M, Canizares CA, Alvarez C. Power generation planning of galapagos' microgrid considering electric vehicles and induction stoves. [–1]. *IEEE Trans Sustain Energy* 2018;1. <https://doi.org/10.1109/TSTE.2018.2876059>.
- [13] MIPRO. Cuenca da primeros pasos para la inserción de vehículos eléctricos. <<https://www.eltiempo.com.ec/noticias/cuenca/2/inicio-estudios-en-cuenca-para-instalar-electrolineras>> [Accessed 2 February 2018]; 2015.
- [14] Cooperativa con taxis eléctricos ya opera en Loja | Ecuador | Noticias | El Universo n.d. <<https://www.eluniverso.com/noticias/2017/05/01/nota/6162826/cooperativa-taxis-electricos-ya-opera-loja>> [Accessed 2 March 2018].
- [15] Martínez-Lao J, Montoya FG, Montoya MG, Manzano-Agugliaro F. Electric vehicles in Spain: an overview of charging systems. *Renew Sustain Energy Rev* 2017;77:970–83. <https://doi.org/10.1016/J.RSER.2016.11.239>.
- [16] Model 3 | Tesla n.d. <<https://www.tesla.com/model3>> [Accessed 5 February 2019].
- [17] Wager G, Whale J, Brauml T. Driving electric vehicles at highway speeds: the effect of higher driving speeds on energy consumption and driving range for electric vehicles in Australia. *Renew Sustain Energy Rev* 2016;63:158–65. <https://doi.org/10.1016/J.RSER.2016.05.060>.
- [18] Sustainable Mobility Initiative n.d. <<https://www.nrel.gov/transportation/sustainable-mobility-initiative.html>> [Accessed 15 January 2019].
- [19] Espinoza JL, Gonzalez LG, Sempertegui R. Micro grid laboratory as a tool for research on non-conventional energy sources in Ecuador. In: Proceedings of the int. autumn meet. power. electron. comput., IEEE; 2017, p. 1–7. <<https://www.doi.org/10.1109/ROPEC.2017.8261615>>.
- [20] Laboratorios en función de la movilidad eléctrica | UPB n.d. <<https://www.upb.edu.co/es/noticias/laboratorios-en-funcion-de-la-movilidad-electrica>> [Accessed 15 March 2018].
- [21] Chellaswamy C, Ramesh R. Future renewable energy option for recharging full electric vehicles. *Renew Sustain Energy Rev* 2017;76:824–38. <https://doi.org/10.1016/J.RSER.2017.03.032>.
- [22] Liu L, Kong F, Liu X, Peng Y, Wang Q. A review on electric vehicles interacting with renewable energy in smart grid. *Renew Sustain Energy Rev* 2015;51:648–61. <https://doi.org/10.1016/J.RSER.2015.06.036>.
- [23] Nunes P, Figueiredo R, Brito MC. The use of parking lots to solar-charge electric vehicles. *Renew Sustain Energy Rev* 2016;66:679–93. <https://doi.org/10.1016/J.RSER.2016.08.015>.
- [24] Chandra Mouli GR, Bauer P, Zeman M. System design for a solar powered electric vehicle charging station for workplaces. *Appl Energy* 2016;168:434–43. <https://doi.org/10.1016/J.APENERGY.2016.01.110>.
- [25] Hoarau Q, Perez Y. Interactions between electric mobility and photovoltaic generation: a review. *Renew Sustain Energy Rev* 2018;94:510–22. <https://doi.org/10.1016/J.RSER.2018.06.039>.
- [26] Takafumi Anegawa. Development of quick charging system for electric vehicle. Montreal, Quebec: World Energy Congr.; 2010. [doi:ISBN: 978-1-61738-736-4].
- [27] Khaligh A, Dusmez S. Comprehensive Topological Analysis of Conductive and Inductive Charging Solutions for Plug-In Electric Vehicles. *IEEE Trans Veh Technol* 2012;61:3475–89. <https://doi.org/10.1109/TVT.2012.2213104>.

- [28] Smith M, Castellano J. Costs associated with non-residential electric vehicle supply equipment. US Dep Energy's. <https://afdc.energy.gov/files/u/publication/evse_cost_report_2015.pdf> [Accessed 2 March 2018]; 2015.
- [29] Francfort J. IEA IA-HEV: DC fast charger use, fees, battery impacts and temperature impacts on charge rates n.d. <https://avt.inl.gov/sites/default/files/pdf/presentations/IEA_DCFCImpactStudySept2014.pdf> [Accessed 2 March 2018]; 2014.
- [30] Habib S, Kamran M, Rashid U. Impact analysis of vehicle-to-grid technology and charging strategies of electric vehicles on distribution networks - a review. *J Power Sources* 2015;277:205–14. <<https://doi.org/10.1016/j.jpowsour.2014.12.020>>.
- [31] Shaikat N, Khan B, Ali SM, Mehmood CA, Khan J, Farid U, et al. A survey on electric vehicle transportation within smart grid system. *Renew Sustain Energy Rev* 2018;81:1329–49. <<https://doi.org/10.1016/J.RSER.2017.05.092>>.
- [32] Morais H, Sousa T, Vale Z, Faria P. Evaluation of the electric vehicle impact in the power demand curve in a smart grid environment. *Energy Convers Manag* 2014;82:268–82. <<https://doi.org/10.1016/J.ENCONMAN.2014.03.032>>.
- [33] Tan KM, Ramachandaramurthy VK, Yong JY. Integration of electric vehicles in smart grid: a review on vehicle to grid technologies and optimization techniques. *Renew Sustain Energy Rev* 2016;53:720–32. <<https://doi.org/10.1016/J.RSER.2015.09.012>>.
- [34] IEEE Std 2030.1.1-2015. IEEE Standard technical specifications of a DC quick charger for use with electric vehicles. IEEE; 2016.
- [35] IEC 61851-23:2014 | IEC Webstore | LVDC n.d. <<https://webstore.iec.ch/publication/6032>> [Accessed 5 February 2019].
- [36] J1772: SAE Electric Vehicle Conductive Charge Coupler - SAE International n.d. <https://www.sae.org/standards/content/j1772_199610/> [Accessed 5 February 2019].
- [37] Schwarzer V, Ghorbani R. Current state-of-the-art of EV Chargers. <<https://www.hnei.hawaii.edu/sites/www.hnei.hawaii.edu/files/CurrentStateoftheArtEVChargers.pdf>> [Accessed 2 February 2018]; 2015.
- [38] IEC 61851-1:2017. | IEC Webstore n.d. <<https://webstore.iec.ch/publication/33644>> [Accessed 8 February 2019].
- [39] Nic Lutsey, Peter Slowik, Jin Lingzhi. Sustaining electric vehicle market growth in U.S. cities | International council on clean transportation. International Council Clean Transp. <<https://www.theicct.org/leading-us-city-electric-vehicle-2016>> [Accessed 8 February 2019].
- [40] Dale Hall, Marissa Moultaq, Nic Lutsey. Electric vehicle capitals of the world: Demonstrating the path to electric drive | International council on clean transportation. <<https://www.theicct.org/publications/EV-capitals-of-the-world>> [Accessed 8 February 2019]; 2017.
- [41] EPRI Product n.d. <<https://www.epri.com/#/pages/product/00000003002004096/?Lang=en-US>> [Accessed 8 February 2019].
- [42] Efthymiou D, Chrysostomou K, Morfoulaki M, Afantopoulou G. Electric vehicles charging infrastructure location: a genetic algorithm approach. *Eur Transp Res Rev* 2017;9:27. <<https://doi.org/10.1007/s12544-017-0239-7>>.
- [43] Nicholas M, Hall D. Lessons learned on early electric vehicle fast-charging deployments | International Council on Clean Transportation n.d. <<https://www.theicct.org/publications/fast-charging-lessons-learned>> [Accessed 8 February 2019].
- [44] 1062 gasolineras para tanquear en Ecuador: El Comercio Data n.d. <<https://especiales.elcomercio.com/2015/10/gasolineras/#>> [Accessed 8 February 2019].
- [45] Estado de las vías de transporte – Ministerio de Transporte y Obras Públicas n.d. <<https://www.obraspublicas.gob.ec/estado-de-las-vias-de-transporte/>> [Accessed 8 February 2019].
- [46] Colmenar-Santos A, de Palacio C, Borge-Diez D, Monzón-Alejandro O, Colmenar-Santos A, De Palacio C, et al. Planning minimum interurban fast charging infrastructure for electric vehicles: methodology and application to Spain. *Energies* 2014;7:1207–29. <<https://doi.org/10.3390/en7031207>>.
- [47] Gnnann T, Funke S, Jakobsson N, Plötz P, Sprei F, Bennehag A. Fast charging infrastructure for electric vehicles: today's situation and future needs. *Transp Res Part D Transp Environ* 2018;62:314–29. <<https://doi.org/10.1016/J.TRD.2018.03.004>>.
- [48] High Power – Chademo Association n.d. <<https://www.chademo.com/technology/high-power/>> [Accessed 8 February 2019].
- [49] Yilmaz M, Krein PT. Review of battery charger topologies, charging power levels, and infrastructure for plug-in electric and hybrid vehicles. *IEEE Trans Power Electron* 2013;28:2151–69. <<https://doi.org/10.1109/TPEL.2012.2212917>>.
- [50] Beres RN, Wang X, Liserre M, Blaabjerg F, Bak CL. A review of passive power filters for three-phase grid-connected voltage-source converters. *IEEE J Emerg Sel Top Power Electron* 2016;4:54–69. <<https://doi.org/10.1109/JESTPE.2015.2507203>>.
- [51] George N, Sebastian E, George R. Practical evaluation of a full-bridge phase-shift-modulated ZVS DC-DC Converter. *Int J Adv Res Electr Electron Instrum Energy* 1970;3.
- [52] Hossain MZ, Rahim NA, Selvaraj J a/l. Recent progress and development on power DC-DC converter topology, control, design and applications: a review. *Renew Sustain Energy Rev* 2018;81:205–30. <<https://doi.org/10.1016/J.RSER.2017.07.017>>.
- [53] PSIM® User's Guide. Powersim. <<https://powersimtech.com/drive/uploads/2016/06/PSIM-User-Manual.pdf>> [Accessed 8 February 2019]; 2016.
- [54] Ceylan M, Sarikurt T, Balıkcı A. A novel lithium-ion-polymer battery model for hybrid/electric vehicles. In: Proceedings of the international symp. ind. electron., IEEE, 2014, p. 366–369. <<https://www.doi.org/10.1109/ISIE.2014.6864640>>.
- [55] Instituto nacional de estadística y censos. Resultados del Censo 2010 de población y vivienda en el Ecuador; 2010. <<http://www.ecuadorencifras.gob.ec/wp-content/descargas/Manu-lateral/Resultados-provinciales/azuay.pdf>>.
- [56] Manzano F, Velázquez GÁ. La evolución de las ciudades intermedias en la Argentina. *Geo UERJ* 2017. <<https://doi.org/10.12957/GEOUERJ>>.
- [57] Electricidad A de regulación y control de. Estadística anual y multianual del sector eléctrico Ecuatoriano n.d. <<https://www.regulacionelectrica.gob.ec/wp-content/uploads/downloads/2017/08/Estadística-anual-y-multianual-sector-eléctrico-2016.pdf>>.
- [58] Jin JS. Installing public electric vehicle charging stations: a site suitability analysis in Los Angeles County, California; 2016.
- [59] Park E, Kwon SJ. Renewable electricity generation systems for electric-powered taxis: the case of Daejeon metropolitan city. *Renew Sustain Energy Rev* 2016;58:1466–74. <<https://doi.org/10.1016/j.rser.2015.12.308>>.
- [60] Mahmoud M, Garnett R, Ferguson M, Kanaroglou P. Electric buses: a review of alternative powertrains. *Renew Sustain Energy Rev* 2016;62:673–84. <<https://doi.org/10.1016/j.rser.2016.05.019>>.
- [61] Espinoza Sibri VG, Ortega Lema EP, Sancho Carchipulla MV. Estudio de la vida útil de los vehículos desde la perspectiva de la gestión de mantenimiento del transporte público modalidad taxis de la ciudad de Cuenca; 2012.
- [62] Take charge, a road map to electric new york city taxis n.d. www.nyc.gov/.../electric_taxi:task_force_report_20131231.pdf#0A%0A [Accessed 2 May 2018].
- [63] Ingeniería CDE, Automotriz M. Evaluación de impacto vial en Av. Fray Vicente Solano, operación vehicular y ciclovía; 2016.
- [64] Deb S, Tammi K, Kalita K, Mahanta P, Deb S, Tammi K, et al. Impact of electric vehicle charging station load on distribution network. *Energies* 2018;11:178. <<https://doi.org/10.3390/en11010178>>.
- [65] NT: 519-2014 IEEE Recommended Practice and Requirements for Harmonic Control in Electric Power Systems. n.d.